

Rear bumper - underrun protection

Lifting



R58 - 03

In detail

- For regular or 4x4 trucks
- 2 lengths of predrilled arms, to be shortened if required
- Fixing plates onto the chassis frame only with 4 bolts
- Light hexagonal profile
- Lowering and lifting assisted by two gas struts protected against shocks
- Closing by automatic bolt in lower and upper positions
- Cataphoresis (KTL) finish



2 GAS STRUTS



2 AUTOMATIC LOCKING BOLTS

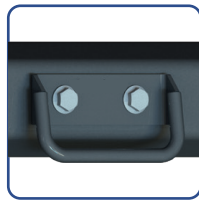

OPTIONAL OPERATING HANDLE

Description	Length (mm)	Height (mm)	Weight (kg)
Hexagonal profile + brackets	2320	126	50
Hexagonal profile	2320	126	42
Brackets + screws			8.5
DAF and Iveco fixing plates	395	260	20
MAN, Mercedes, Scania, Renault and Volvo Trucks fixing plates	395	260	20
Short pre-drilled arms		680	29
Long pre-drilled arms		830	34
Gas strut 700 N			1
Gas strut 1 100 N			1
Gas strut 1 500 N			1
Handle			0.5
M14 screw set			5.5
M16 screw set			7

DRAWING

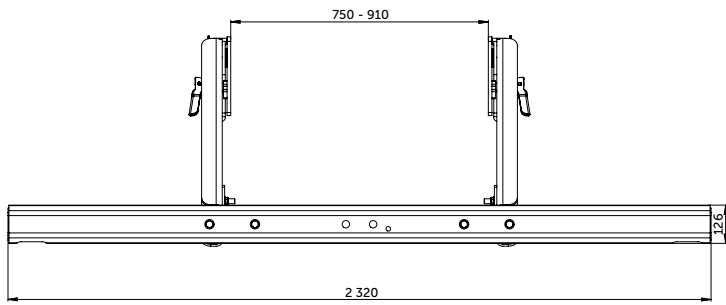

SET-UP



SHORT ARMS 680 mm

Arms can be shortened by 50 mm up to a minimum of 30 mm from the last hole.

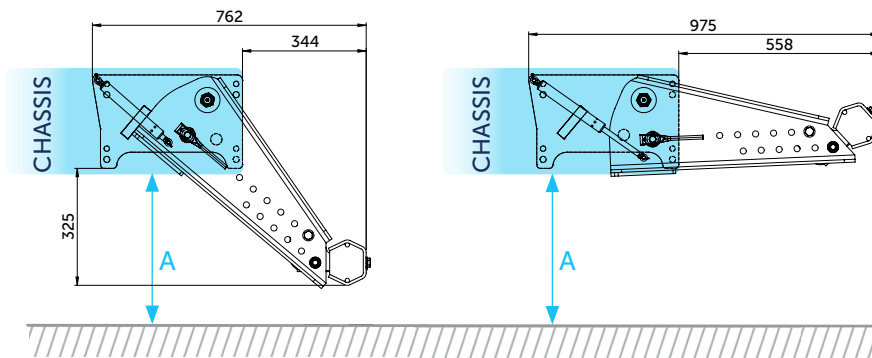

A max. (mm)

Pneumatic suspension	776
Mechanical suspension	826

LONG ARMS 830 mm

Arms can be shortened by 50 mm up to a minimum of 30 mm from the last hole.

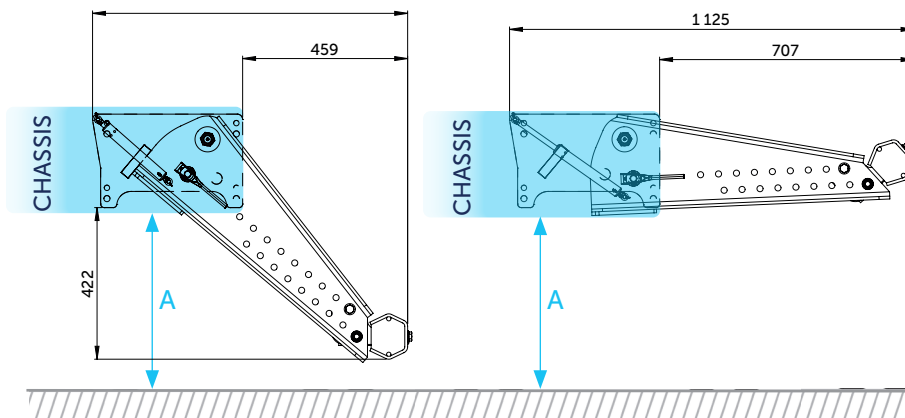

A max. (mm)

Pneumatic suspension	872
Mechanical suspension	922

FIXING PLATES

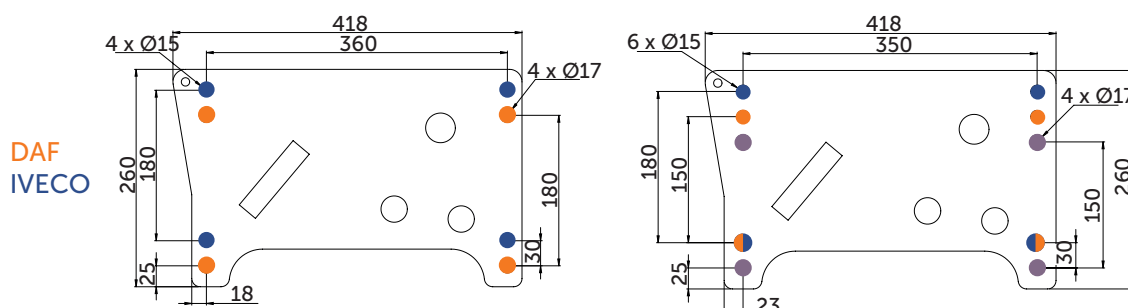

MAN
MERCEDES
RENAULT TRUCKS
SCANIA
VOLVO TRUCKS